

REDUKCE

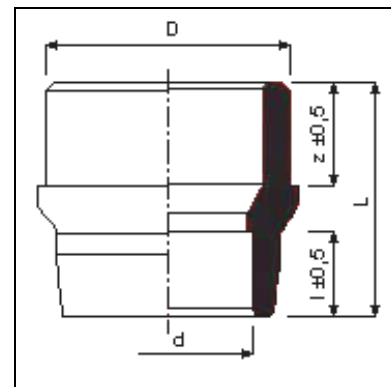

D/d	z	l	L	Hmotnost v kg
50/40	28	26,0	66,0	0,069
50/32	29	22,0	63,0	0,054
63/50	31	31,0	77,0	0,116
63/40	36	26,0	78,0	0,108
63/32	36	22,0	78,0	0,093
75/63	40	37,5	97,0	0,232
90/75	49	43,5	108,5	0,324
90/63	49	37,5	94,5	0,265
90/50	55	31,0	104,0	0,255
90/40	56	26,0	109,0	0,267
90/32	57	22,0	114,0	0,270
110/90	60	51,0	131,0	0,560
110/63	67	37,5	131,5	0,459
110/50	67	31,0	135,0	0,430



HRDLOVÝ NÁTRUBEK



d	l	L	hmotnost v kg
32	22,0	57	0,040
40	26,0	55	0,055
50	31,0	65	0,110
63	37,5	78	0,200
75	43,5	90	0,268
90	51,0	105	0,470
110	61,0	125	0,540

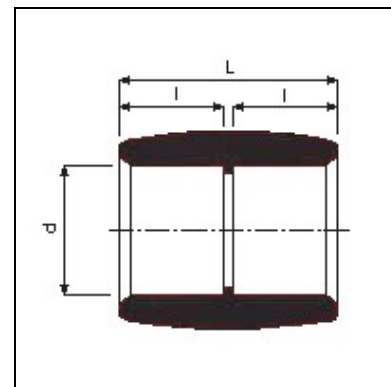

KOLENO 90°



d	l	z	L	hmotnost v kg
32	22,0	17,0	39,0	0,065
40	26,0	21,0	47,0	0,095
50	31,0	26,0	57,0	0,225
63	37,5	32,5	70,0	0,370

Používá se pro polyfúzní svařování

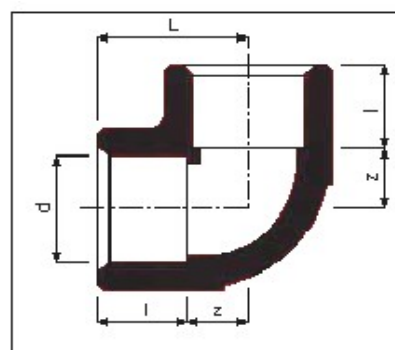

d	L	t
75	min. 75	6,8
90	min. 90	8,2
110	min. 110	10,0

Používá se pro svařování na tupu

