

TVAROVKY Z PP

Tvarovky jsou vyráběny z PP a jsou určeny pro spojování, odbočování a zakončení potrubního vedení. Spojování se provádí navařením a to jednak natupo nebo polyfuzně. Při sváření je třeba dodržovat normu STN 05 6816.

LEMOVÝ NÁKRUŽEK

DN	d	D	D ₁	t	s	L	t ₁	R	hmotnost v kg
32	40	78	46	10	1	70	6,7	2	0,084
40	50	88	56	11	1	75	8,3	3	0,115
50	63	102	69	11	1	84	10,5	3	0,162
65	75	122	81	14	1	94	6,8	3	0,275
80	90	138	96	16	-	56	8,2	4	0,278
100	110	153	116	16	-	64	10,0	5	0,322
150	160	212	175	24	-	70	14,6	10	0,467

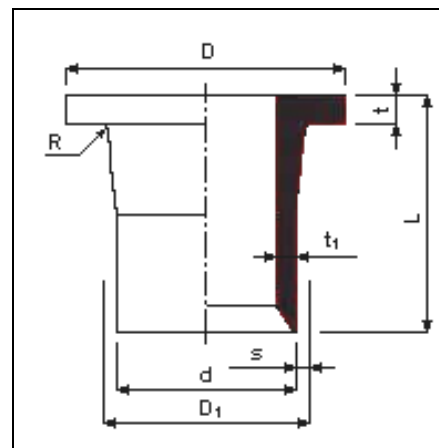

TVAROVKA T

DN	d	l	z	L	hmotnost v kg
25	32	22,0	17,0	78	0,128
32	40	26,0	21,0	94	0,131
40	50	31,0	26,0	114	0,220
50	63	37,5	32,5	140	0,440
65	75	43,5	38,5	167	0,610
80	90	51,0	46,0	167	0,790
100	110	61,0	60,0	242	2,020

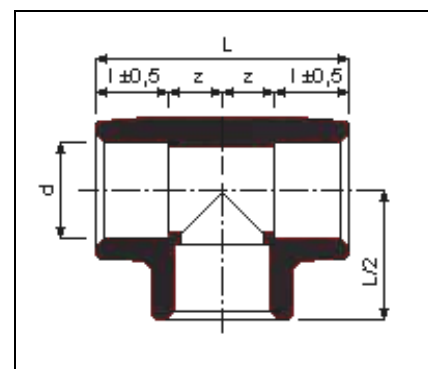

REDUKCE

DN/DN	D/d	L ₁	l	z	L	hmotnost v kg
40/32	50/40	28	26,0	12,0	66,0	0,139
50/40	63/50	31	31,0	15,0	77,0	0,116
50/32	63/40	36	26,0	16,0	78,0	0,095
63/50	75/63	40	37,5	19,5	97,0	0,219
80/63	90/75	49	43,8	16,0	108,8	0,324
80/50	90/63	49	37,5	8,0	94,5	0,265
80/40	90/50	55	31,0	18,0	104,0	0,255
80/32	90/40	56	26,0	27,0	109,0	0,267
100/80	110/90	60	51,0	20,0	131,0	0,610
100/50	110/63	67	37,5	27,0	131,5	0,459
100/40	110/50	67	31,0	37,0	135,0	0,430

